

STANDARD ADAPTERS

Straight Male Adapter Shanks For Female Caps

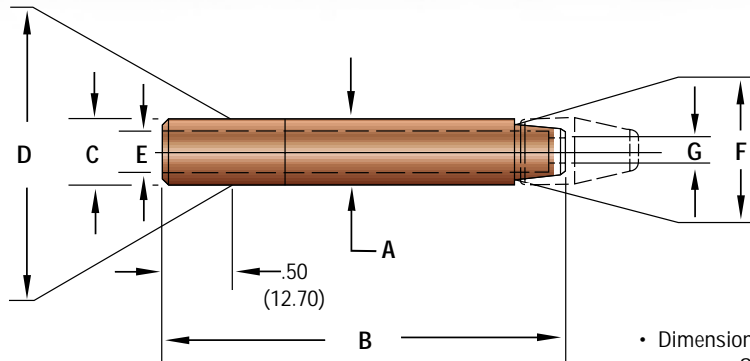

• Dimensions Shown Are: inches (mm).
• See pg. 3-1 For Caps.

FIGURE 4-1 (Material RWMA Class 2 & 3)

ITEM NO.	DIMENSIONS						
	A Major Diameter	B Shank Overall Length	C Minor Taper Diameter	D Gauging Taper Diameter	E Water Hole Diameter	F Cap End Taper Diameter	G Taper Water Hole Diameter
CLF-2405T		1.25 (31.75)					
CLF-2406T		1.50 (38.10)					
CLF-2407T		1.75 (44.45)					
CLF-2408T		2.00 (50.80)					
CLF-2409T		2.25 (57.15)					
CLF-2410T		2.50 (63.50)					
CLF-2411T	.482 (12.24)	2.75 (69.85)	.438 (11.13)	.463 (11.76)	.28 (7.14)	.402 (10.21)	.25 (6.35)
CLF-2412T		3.00 (76.20)					
CLF-2413T		3.25 (82.55)					
CLF-2414T		3.50 (88.90)					
CLF-2415T		3.75 (95.25)					
CLF-2416T		4.00 (101.60)					
CLF-2506T		1.43 (36.32)					
CLF-2507T		1.68 (42.67)					
CLF-2508T		1.93 (49.02)					
CLF-2509T		2.18 (55.37)					
CLF-2510T		2.43 (61.72)					
CLF-2511T	.625 (15.88)	2.68 (68.02)	.588 (14.94)	.613 (15.57)	.34 (8.73)	.502 (12.75)	.265 (6.73)
CLF-2512T		2.93 (74.42)					
CLF-2513T		3.18 (80.77)					
CLF-2514T		3.43 (87.12)					
CLF-2515T		3.68 (93.47)					
CLF-2516T		3.93 (99.82)					

STANDARD ADAPTERS

Straight Male Adapter Shanks For Female Caps

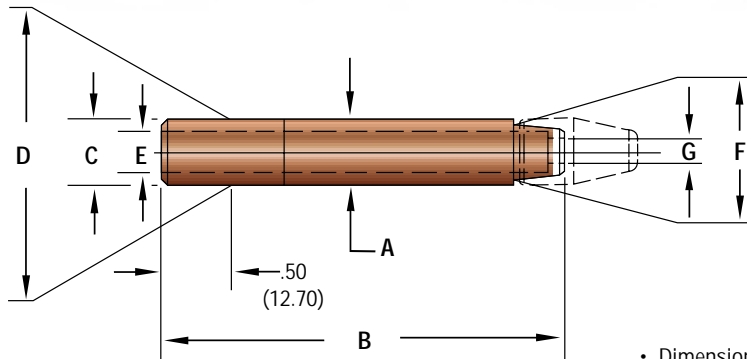

• Dimensions Shown Are: inches (mm).
• See pg. 3-1 For Caps.

FIGURE 4-2 (Material RWMA Class 2 & 3)

ITEM NO.	DIMENSIONS						
	A Major Diameter	B Shank Overall Length	C Minor Taper Diameter	D Gauging Taper Diameter	E Water Hole Diameter	F Major Female Taper Diameter	G Taper Water Hole Diameter
CLF-2608T		2.00 (50.80)					
CLF-2610T		2.50 (63.50)					
CLF-2612T	.750 (19.05)	3.00 (76.20)	.706 (17.93)	.731 (18.57)	.38 (9.53)	.633 (16.08)	.343 (8.71)
CLF-2614T		3.50 (88.90)					
CLF-2616T		4.00 (101.60)					
CLF-2708T		2.00 (50.80)					
CLF-2710T		2.50 (63.50)					
CLF-2712T	.875 (22.23)	3.00 (76.20)	.819 (20.80)	.844 (21.44)	.38 (9.53)	.633 (16.08)	.343 (8.71)
CLF-2714T		3.50 (88.90)					
CLF-2716T		4.00 (101.60)					

FOR ALL OTHER ITEMS:

- Check Key To Item Numbers For Availability
- Use Example For Ordering Available Items

• ADDITIONAL LENGTHS ARE AVAILABLE UPON REQUEST.

KEY TO ITEM NUMBERS

- CLF - Adapter Designation
- 2 or 3 - RWMA Alloy Class
- 4 Thru 7 - RW Taper Number
- 05 Thru 16 - Overall Length in .25 (6.35) Increments
- T - Thru Water Hole
- Delete "T" If Blind Hole Is Required

EXAMPLE:

MALE ADAPTER, CLASS 2, RW 6 TAPER, 2.50 (63.50) O.A.L., THRU WATER HOLE

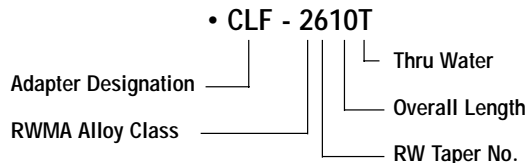

STANDARD ADAPTERS

Straight Female Adapter Shanks For Male Caps

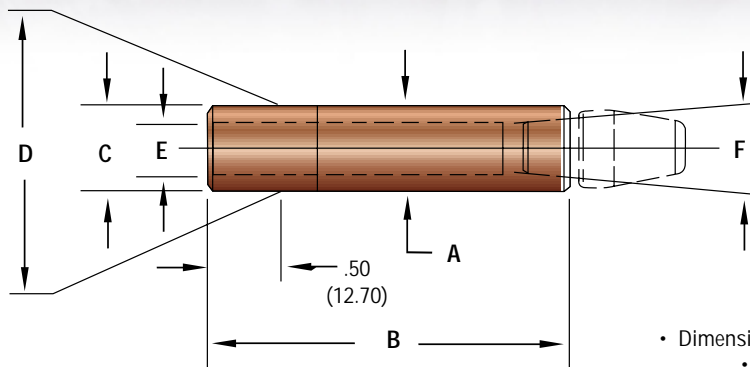

- Dimensions Shown Are: inches (mm).
- See pg. 3-2 For Caps.

FIGURE 4-3 (Material RWMA Class 2 & 3)

ITEM NO.	DIMENSIONS					
	A Major Diameter	B Shank Overall Length	C Minor Taper Diameter	D Gauging Taper Diameter	E Water Hole Diameter	F Major Female Taper Diameter
WG-2405		1.25 (31.75)				
WG-2406		1.50 (38.10)				
WG-2407		1.75 (44.45)				
WG-2408		2.00 (50.80)				
WG-2409		2.25 (57.15)				
WG-2410		2.50 (63.50)				
WG-2411	.482 (12.24)	2.75 (69.85)	.438 (11.13)	.463 (11.76)	.28 (7.14)	.375 (9.53)
WG-2412		3.00 (76.20)				
WG-2413		3.25 (82.55)				
WG-2414		3.50 (88.90)				
WG-2415		3.75 (95.25)				
WG-2416		4.00 (101.60)				
WG-2505		1.25 (31.75)				
WG-2506		1.50 (38.10)				
WG-2507		1.75 (44.45)				
WG-2508		2.00 (50.80)				
WG-2509		2.25 (57.15)				
WG-2510		2.50 (63.50)				
WG-2511	.625 (15.88)	2.75 (69.85)	.588 (14.94)	.613 (15.57)	.38 (9.53)	.415 (10.54)
WG-2512		3.00 (76.20)				
WG-2513		3.25 (82.55)				
WG-2514		3.50 (88.90)				
WG-2515		3.75 (95.25)				
WG-2516		4.00 (101.60)				

• ADDITIONAL LENGTHS ARE AVAILABLE UPON REQUEST.

STANDARD ADAPTERS

Straight Female Adapter Shanks For Male Caps

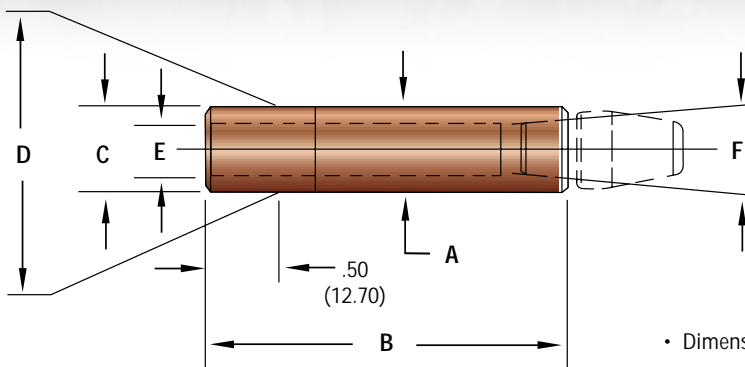

- Dimensions Shown Are: inches (mm).
- See pg. 3-2 For Caps.

FIGURE 4-4 (Material RWMA Class 2 & 3)

ITEM NO.	DIMENSIONS					
	A Major Diameter	B Shank Overall Length	C Minor Taper Diameter	D Gauging Taper Diameter	E Water Hole Diameter	F Major Female Taper Diameter
WG-2608		2.00 (50.80)				
WG-2610		2.50 (63.50)				
WG-2612	.750 (19.05)	3.00 (76.20)	.706 (17.93)	.731 (18.57)	.44 (11.11)	.501 (12.73)
WG-2614		3.50 (88.90)				
WG-2616		4.00 (101.60)				
WG-2708		2.00 (50.80)				
WG-2710		2.50 (63.50)				
WG-2712	.875 (22.23)	3.00 (76.20)	.819 (20.80)	.844 (21.44)	.50 (12.70)	.613 (15.57)
WG-2714		3.50 (88.90)				
WG-2716		4.00 (101.60)				

• ADDITIONAL LENGTHS ARE AVAILABLE UPON REQUEST.

FOR ALL OTHER ITEMS:

- Check Key To Item Numbers For Availability
- Use Example For Ordering Available Items

KEY TO ITEM NUMBERS

- WG - Adapter Designation
- 2 or 3 - RWMA Alloy Class
- 4 Thru 7 - RW Taper Number
- 05 Thru 16 - Overall Length in .25 (6.35) Increments

EXAMPLE:

FEMALE ADAPTER, CLASS 3, RW 4 TAPER, 1.25 (31.75) O.A.L.

• **WG - 3405**

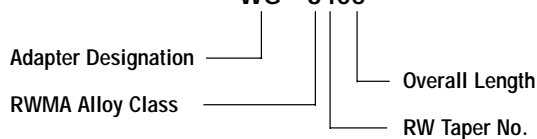

STANDARD ADAPTERS

Offset Male Adapter Shanks For Female Caps

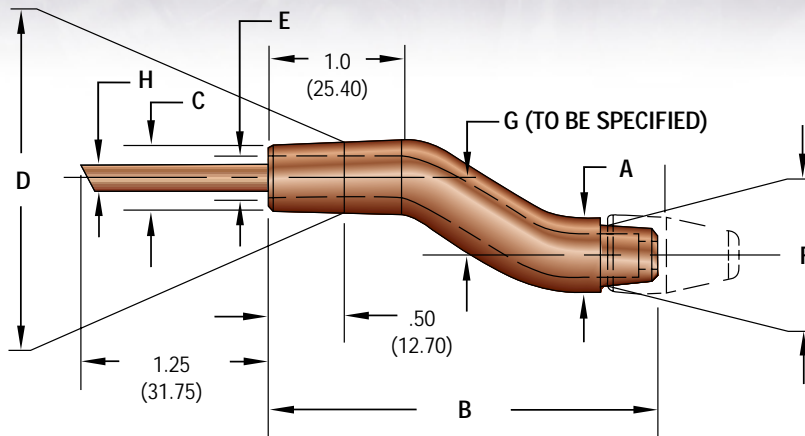

FIGURE 4-5 (Material RWMA Class 2 & 3)

• Dimensions Shown Are: inches (mm).
• See pg. 3-1 For Caps.

ITEM NO.	DIMENSIONS							
	A Major Diameter	B Shank Overall Length	C Minor Taper Diameter	D Gauging Taper Diameter	E Water Hole Diameter	F Cap End Taper Diameter	G Offset	H Water Tube Diameter
CLF-2410-04T		2.50 (63.50)					.25 (6.35)	
CLF-2411-04T		2.75 (69.85)					.25 (6.35)	
CLF-2412-04T		3.00 (76.20)					.25 (6.35)	
CLF-2413-04T		3.25 (82.55)					.25 (6.35)	
CLF-2410-08T	.482 (12.24)	2.50 (63.50)	.438 (11.13)	.463 (11.76)	.28 (7.14)	.402 (10.21)	.50 (12.70)	.19 (4.76)
CLF-2411-08T		2.75 (69.85)					.50 (12.70)	
CLF-2412-08T		3.00 (76.20)					.50 (12.70)	
CLF-2413-08T		3.25 (82.55)					.50 (12.70)	
CLF-2510-04T		2.50 (63.50)					.25 (6.35)	
CLF-2511-04T		2.75 (69.85)					.25 (6.35)	
CLF-2512-04T		3.00 (76.20)					.25 (6.35)	
CLF-2513-04T		3.25 (82.55)					.25 (6.35)	
CLF-2510-08T	.625 (15.88)	2.50 (63.50)	.588 (14.94)	.613 (15.57)	.34 (8.73)	.502 (12.75)	.50 (12.70)	.25 (6.35)
CLF-2511-08T		2.75 (69.85)					.50 (12.70)	
CLF-2512-08T		3.00 (76.20)					.50 (12.70)	
CLF-2513-08T		3.25 (82.55)					.50 (12.70)	

FOR ALL OTHER ITEMS:

- Check Key To Item Numbers For Availability
- Use Example For Ordering Available Items

• ADDITIONAL LENGTHS ARE AVAILABLE UPON REQUEST.

KEY TO ITEM NUMBERS

- CLF - Adapter Designation
- 2 or 3 - RWMA Alloy Class
- 4 Thru 6 - RW Taper Number
- 10 Thru 20 - Overall Length in .25 (6.35) Increments
- 04 Thru 16 - Offset in .06 (1.59) Increments
- T - Thru Water Hole
- Delete "T" If Blind Hole Is Required

EXAMPLE:

MALE ADAPTER, CLASS 3,
RW 4 TAPER, 2.50 (63.50) O.A.L., .25 (6.35) OFFSET, THRU WATER HOLE

• CLF - 3410 - 04T

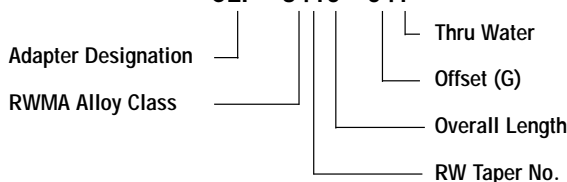

STANDARD ADAPTERS

Offset Female Adapter Shanks for Male Caps

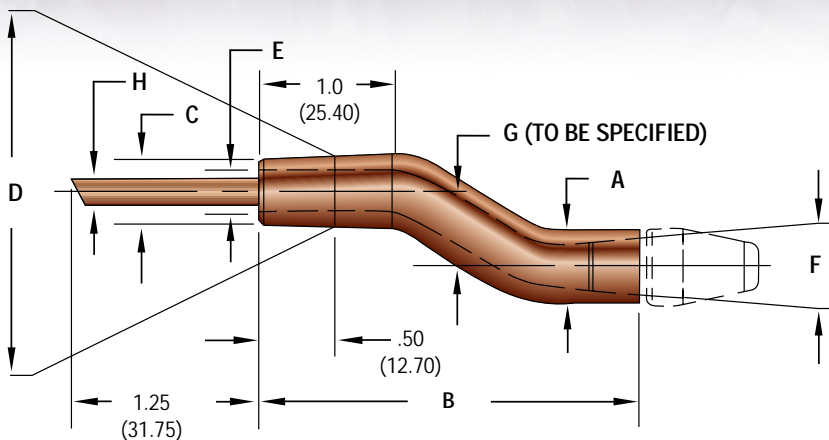

FIGURE 4-6 (Material RWMA Class 2 & 3)

• Dimensions Shown Are: inches (mm).
• See pg. 3-2 For Caps.

ITEM NO.	DIMENSIONS							
	A Major Diameter	B Shank Overall Length	C Minor Taper Diameter	D Gauging Taper Diameter	E Water Hole Diameter	F Cap End Taper Diameter	G Offset	H Water Tube Diameter
WG-2410-04		2.50 (63.50)					.25 (6.35)	
WG-2411-04		2.75 (69.85)					.25 (6.35)	
WG-2412-04		3.00 (76.20)					.25 (6.35)	
WG-2413-04		3.25 (82.55)					.25 (6.35)	
WG-2410-08	.482 (12.24)	2.50 (63.50)	.438 (11.13)	.463 (11.76)	.28 (7.14)	.375 (9.53)	.50 (12.70)	.19 (4.76)
WG-2411-08		2.75 (69.85)					.50 (12.70)	
WG-2412-08		3.00 (76.20)					.50 (12.70)	
WG-2413-08		3.25 (82.55)					.50 (12.70)	
WG-2510-04		2.50 (63.50)					.25 (6.35)	
WG-2511-04		2.75 (69.85)					.25 (6.35)	
WG-2512-04		3.00 (76.20)					.25 (6.35)	
WG-2513-04		3.25 (82.55)					.25 (6.35)	
WG-2510-08	.625 (15.88)	2.50 (63.50)	.588 (14.94)	.613 (15.57)	.38 (9.65)	.415 (10.54)	.50 (12.70)	.25 (6.35)
WG-2511-08		2.75 (69.85)					.50 (12.70)	
WG-2512-08		3.00 (76.20)					.50 (12.70)	
WG-2513-08		3.25 (82.55)					.50 (12.70)	

FOR ALL OTHER ITEMS:

- Check Key To Item Numbers For Availability
- Use Example For Ordering Available Items

• ADDITIONAL LENGTHS ARE AVAILABLE UPON REQUEST.

EXAMPLE:

FEMALE ADAPTER, CLASS 2,
RW 5 TAPER, 3.25 (82.55) O.A.L., 1.0 (25.40) OFFSET.

• **WG - 2513 - 16**

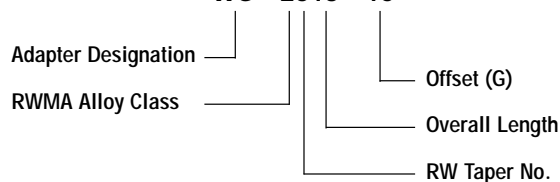

KEY TO ITEM NUMBERS

- WG - Adapter Designation
- 2 or 3 - RWMA Alloy Class
- 4 Thru 6 - RW Taper Number
- 10 Thru 20 - Overall Length
in .25 (6.35) Increments
- 04 Thru 16 - Offset in .06 (1.59) Increments

STANDARD ADAPTERS

Single Bend Male Adapter Shanks For Female Caps

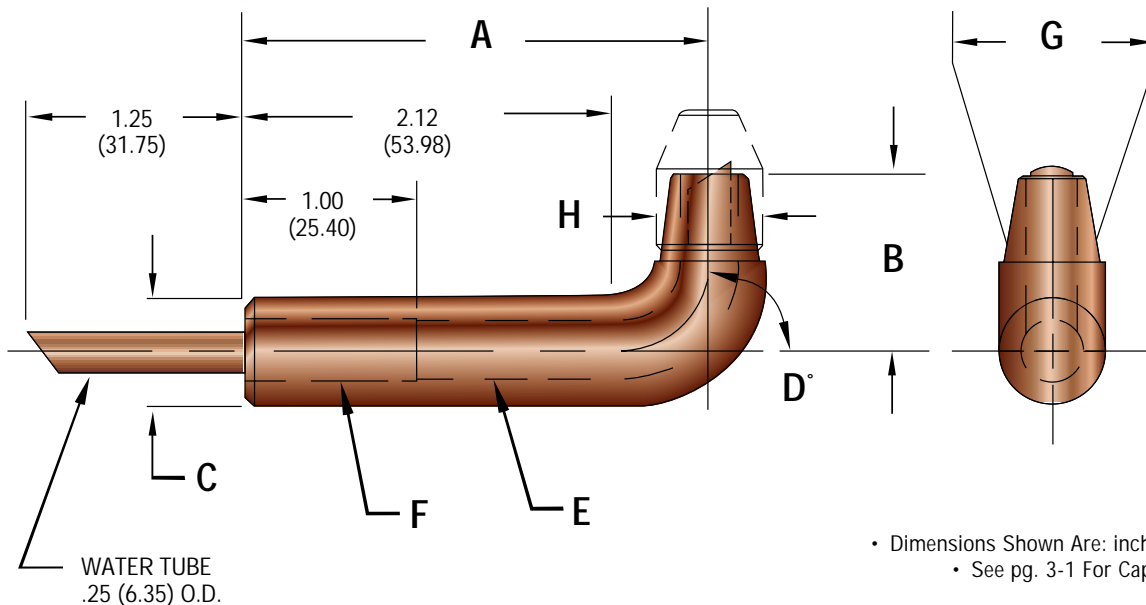

FIGURE 4-7 (Material RWMA Class 3)

DIMENSION CHARTS

C – DIAMETER	.625 (15.88)	.750 (19.05)	.88 (22.35)
DIAMETER CODE	5	6	7
A – OVERALL LENGTH	AS CODED		
B – OFFSET	AS CODED		
D – ANGLE	AS CODED		

H – CAP SIZE	.500 (12.70)	.625 (15.88)	.750 (19.05)
E – HOLE DIAMETER	.28 (7.11)	.31 (7.87)	.34 (8.64)
F – HOLE DIAMETER	.38 (9.65)	.38 (9.65)	.38 (9.65)
G – TAPER DIAMETER	.402 (10.21)	.502 (12.75)	.633 (16.08)

• TO ORDER YOUR SPECIALS USE CODING CHART - SEE PG. 4-8

STANDARD ADAPTERS

Single Bend Male Adapter Shanks For Female Caps

EXAMPLE EXPLANATION CODING

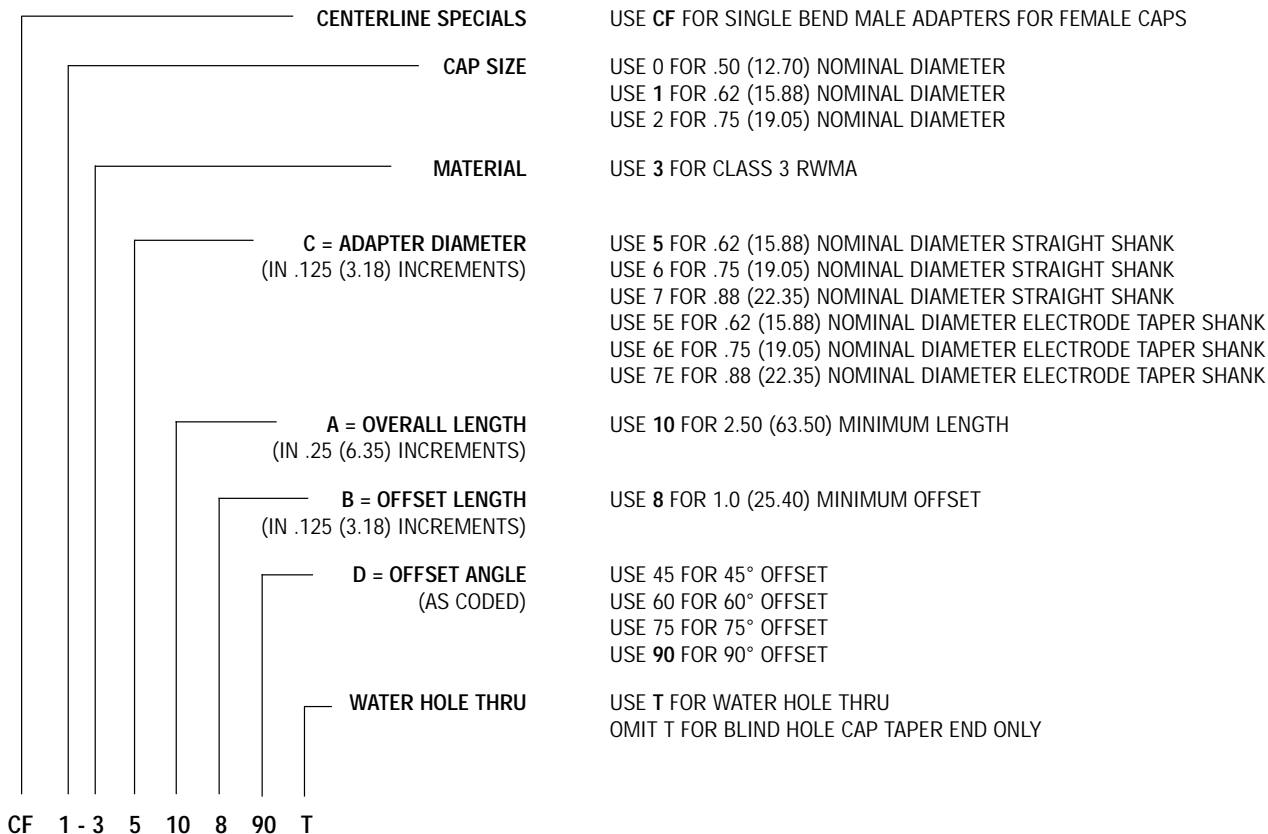

SAMPLE TYPICAL CAP ADAPTER CODING

CAP ADAPTER WATER HOLE WILL BE DRILLED THRU
 CAP ADAPTER OFFSET ANGLE WILL BE 90°
 CAP ADAPTER OFFSET WILL BE 1.0 (25.40) LONG
 CAP ADAPTER WILL BE 2.50 (63.50) LONG
 CAP ADAPTER WILL HAVE .62 (15.88) DIAMETER
 CAP ADAPTER WILL BE MADE OF CLASS 3 RWMA MATERIAL
 CAP ADAPTER WILL HAVE A STRAIGHT SHANK
 CAP ADAPTER WILL BE SINGLE BEND MALE FOR FEMALE CAPS

EXAMPLE:

• CF1-3510890T

• Dimensions Shown Are: inches (mm)

STANDARD ADAPTERS

Single Bend Female Adapter Shanks For Male Caps

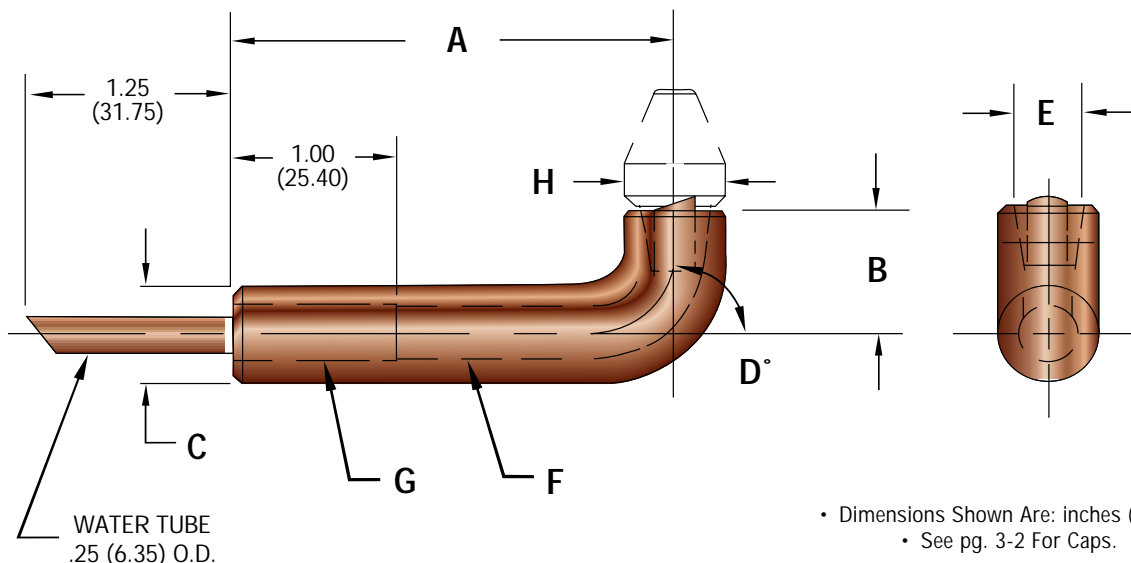

FIGURE 4-8 (Material RWMA Class 3)

DIMENSION CHARTS

C – DIAMETER	.625 (15.88)	.750 (19.05)	.875 (22.23)	1.00 (25.40)
DIAMETER CODE	5	6	7	8
A – OVERALL LENGTH	AS CODED			
B – OFFSET	AS CODED			
D – DIAMETER	AS CODED			

H – CAP SIZE	.500 (12.70)	.625 (15.88)	.750 (19.05)	.875 (22.23)
E – TAPER DIAMETER	.374 (9.50)	.414 (10.52)	.500 (12.70)	.613 (15.57)
F – HOLE DIAMETER	.28 (7.11)	.34 (8.64)	.44 (11.18)	.50 (12.70)
G – HOLE DIAMETER	.38 (9.65)	.38 (9.65)	.44 (11.18)	.50 (12.70)

• TO ORDER YOUR SPECIALS USE CODING CHART - SEE PG. 4-10

STANDARD ADAPTERS

Single Bend Female Adapter Shanks For Male Caps

EXAMPLE EXPLANATION CODING

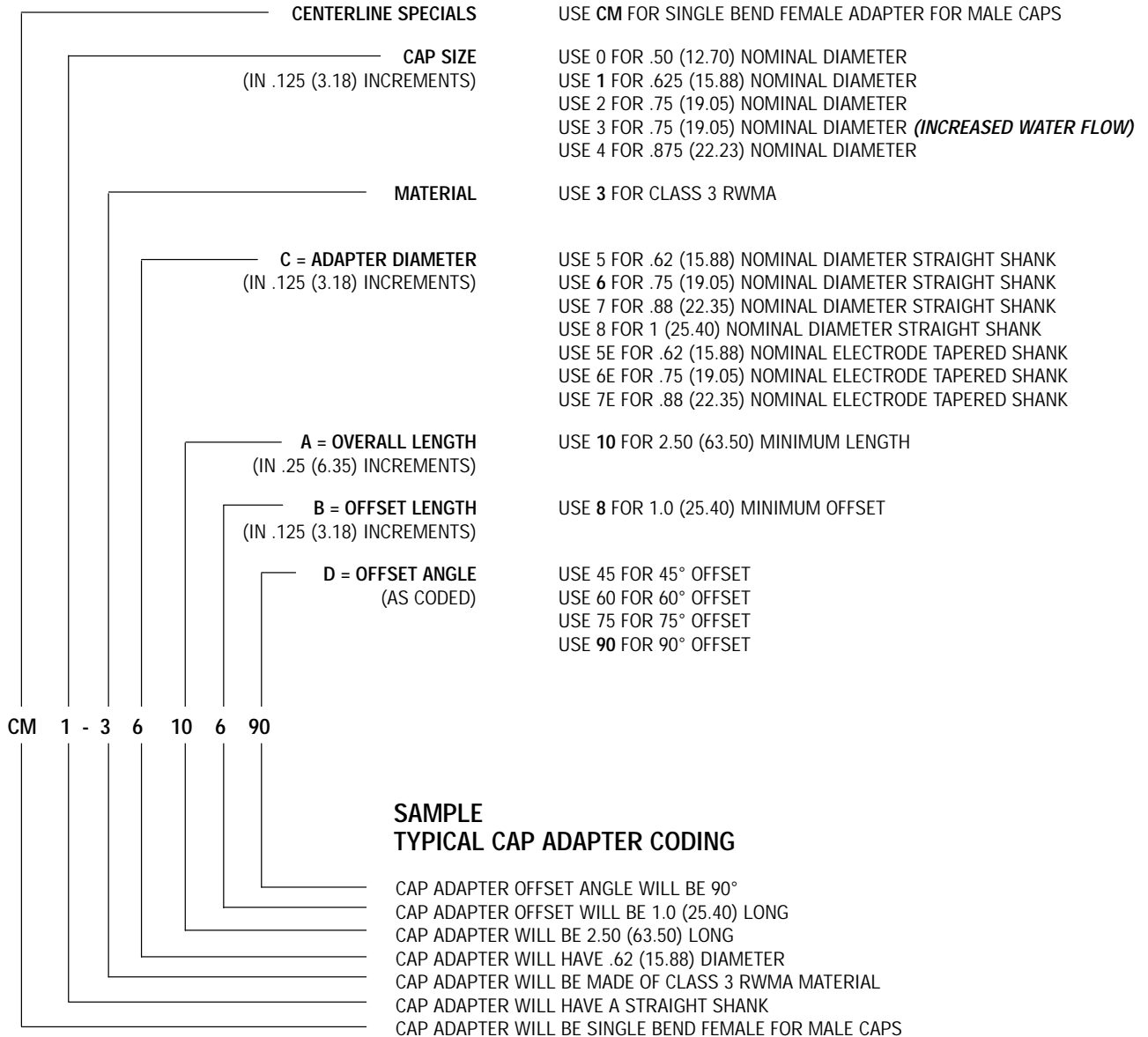

EXAMPLE:

• **CM1-3610690**

• Dimensions Shown Are: inches (mm)

STANDARD ADAPTERS

J Shape Cap Adapters

EXAMPLE:

- CL JA5-35-10166M

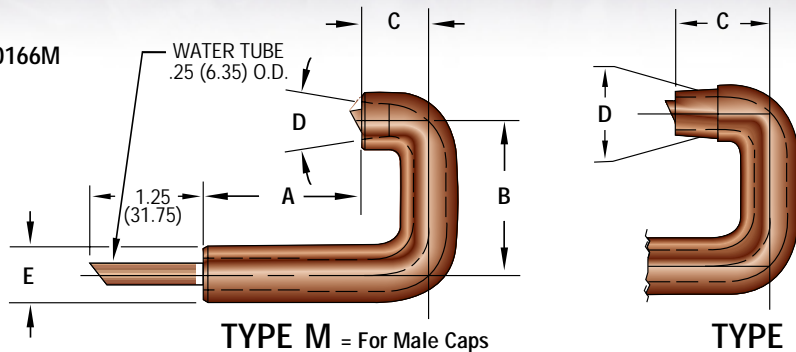

Minimum "C" Dim.

- Type M = .75 (19.05)
- Type F = 1.00 (25.40)

FIGURE 4-9 (Material RWMA Class 3)

- Dimensions Shown Are: inches (mm).
- See pg. 3-1 & 3-2 For Caps

EXAMPLE EXPLANATION CODING

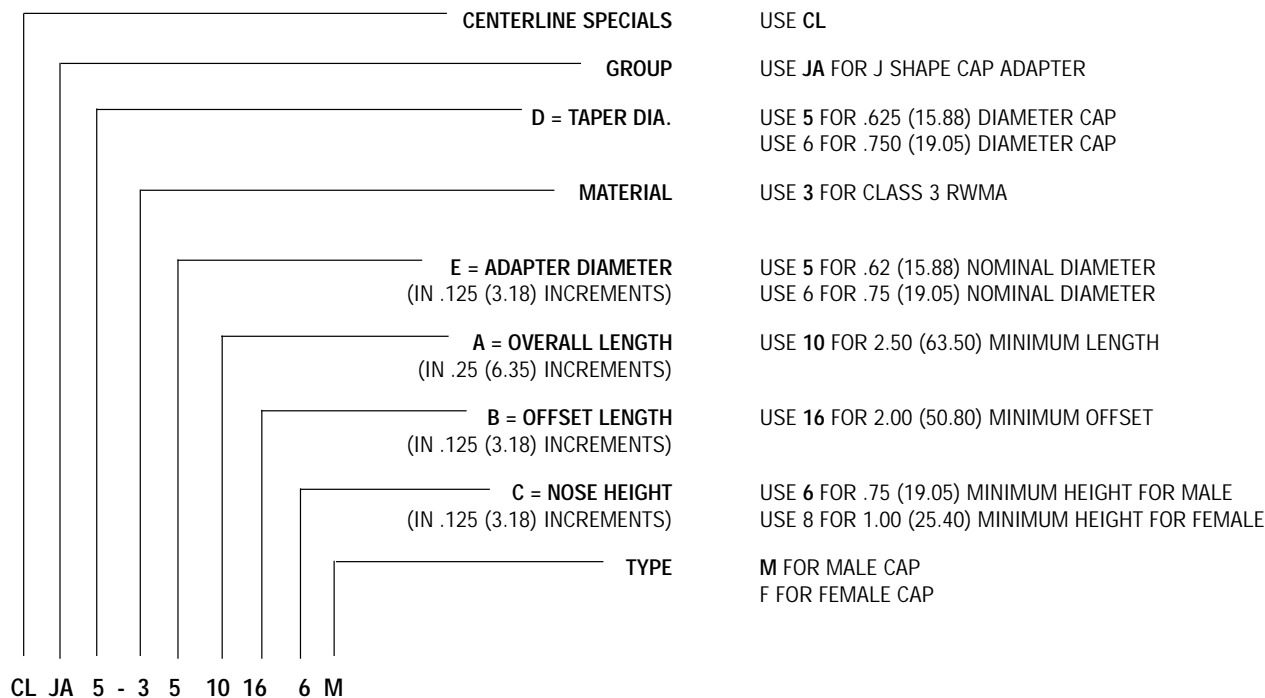

SAMPLE TYPICAL J SHAPE CAP ADAPTER CODING

- CAP ADAPTER TYPE WILL BE FOR MALE CAPS
- CAP ADAPTER NOSE WILL BE .75 (19.05) HIGH
- CAP ADAPTER OFFSET WILL BE 2.00 (50.80) LONG
- CAP ADAPTER WILL BE 2.50 (63.50) LONG
- CAP ADAPTER WILL HAVE .62 (15.88) DIAMETER
- CAP ADAPTER WILL BE MADE OF CLASS 3 RWMA MATERIAL
- CAP ADAPTER NOSE WILL BE .625 (15.88) DIAMETER CAP TAPER
- J SHAPE CAP ADAPTER

STANDARD ADAPTERS

CenterLine Hex Adapters Straight Thread

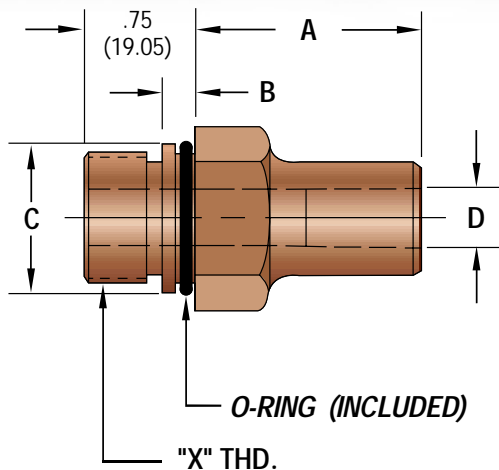

TAPER NO.	D	Minimum A		
		7/8-14	1-12	1-1/4-12
#4RW	0.463 (11.76)	0.25	0.25	0.25
#5RW	0.625 (15.88)	0.25	0.25	0.25
#6RW	0.750 (19.05)	1.13	0.25	0.25
#7RW	0.875 (22.35)	1.38	1.25	0.25

THREAD	"X"	B	C	HEX	O-RING
7/8-14	87	0.25 (6.35)	1 (25.40)	1-1/4	SLORD-117
1-12	10	0.25 (6.35)	1.13 (28.58)	1-1/4	SLORD-119
1-1/4-12	12	0.25 (6.35)	1.38 (34.93)	1-1/2	SLORD-123

FIGURE 4-10 • Dimensions Shown Are: inches (mm).

EXAMPLE:

• **CLHA - 875E10**

HEX ADAPTER, 7/8-14 THD., #5 RW TAPER, ELECTRODE ADAPTER, LENGTH = 1.25 (31.75).

EXAMPLE EXPLANATION CODING

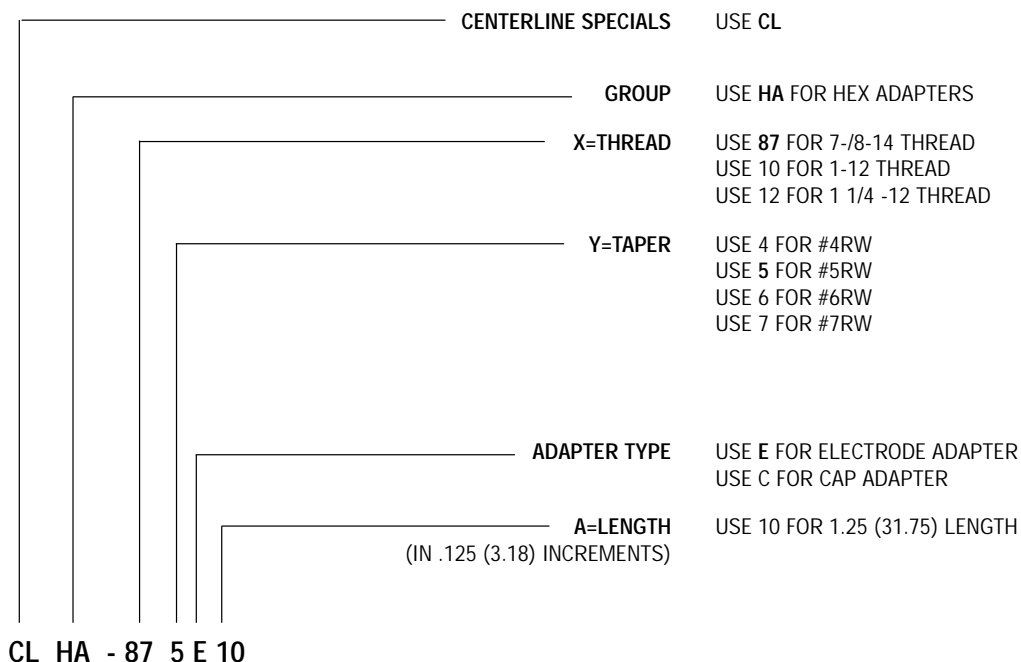

STANDARD ADAPTERS

Cap and Electrode Hex Adapters Pipe Thread

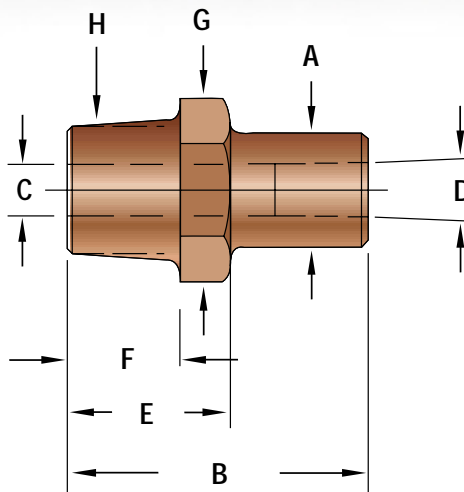

• Dimensions Shown Are: inches (mm).
• See Pg. 3-2 For Caps.

FIGURE 4-11 (Material RWMA Class 2 & 3)

ELECTRODE ADAPTER CHART

ELECTRODE CODE	4	5	4	5	5	6	7
A- DIAMETER	0.88 (22.35)	0.94 (23.88)	0.88 (22.35)	0.94 (23.88)	0.94 (23.88)	1.09 (27.69)	1.24 (31.50)
B- LENGTH	AS CODED						
LENGTH (Minimum)	0.88 (22.35)	0.88 (22.35)	1.00 (25.40)	1.00 (25.40)	1.12 (28.45)	1.12 (28.45)	1.38 (35.05)
C- HOLE DIAMETER	0.42 (10.67)	0.44 (11.18)	0.42 (10.67)	0.44 (11.18)	0.44 (11.18)	0.50 (12.70)	0.56 (14.22)
D- TAPER DIAMETER	0.463 (11.76)	0.625 (15.88)	0.463 (15.88)	0.625 (15.88)	0.625 (15.88)	0.750 (19.05)	0.875 (22.22)
E- HEX LENGTH	0.88 (22.35)	0.88 (22.35)	1.00 (25.40)	1.00 (25.40)	1.38 (35.05)	1.38 (35.05)	1.38 (35.05)
F- THREAD LENGTH	0.62 (15.75)	0.62 (15.75)	0.75 (19.05)	0.75 (19.05)	0.88 (22.35)	0.88 (22.35)	0.88 (22.35)
G- HEX	1.00 (25.40)	1.00 (25.40)	1.00 (25.40)	1.00 (25.40)	1.25 (31.75)	1.25 (31.75)	1.25 (31.75)
H- THREAD (N.P.T.)	1/2	1/2	5/8	5/8	3/4	3/4	3/4

CAP ADAPTER CHART

ELECTRODE CODE	4	5	4	5	5	6	6-1	7
A- DIAMETER	0.50 (12.70)	0.62 (15.75)	0.50 (12.70)	0.62 (15.75)	0.62 (15.75)	0.75 (19.05)	0.75 (19.05)	0.88 (22.35)
B- LENGTH	AS CODED							
LENGTH (Minimum)	0.88 (22.35)	0.88 (22.35)	1.00 (25.40)	1.00 (25.40)	1.12 (28.45)	1.12 (28.45)	1.12 (28.45)	1.12 (28.45)
C- HOLE DIAMETER	0.28 (7.11)	0.38 (9.65)	0.28 (7.11)	0.38 (9.65)	0.38 (9.65)	0.44 (11.18)	0.44 (11.18)	0.56 (14.22)
D- TAPER DIAMETER	0.313 (7.95)	0.414 (10.52)	0.313 (7.95)	0.414 (10.52)	0.414 (10.52)	0.500 (12.70)	0.562 (14.27)	0.700 (17.78)
E- HEX LENGTH	0.88 (22.35)	0.88 (22.35)	1.00 (25.40)	1.00 (25.40)	1.38 (35.05)	1.38 (35.05)	1.38 (35.05)	1.38 (35.05)
F- THREAD LENGTH	0.62 (15.75)	0.62 (15.75)	0.75 (19.05)	0.75 (19.05)	0.88 (22.35)	0.88 (22.35)	0.88 (22.35)	0.88 (22.35)
G- HEX	1.00 (25.40)	1.00 (25.40)	1.00 (25.40)	1.00 (25.40)	1.25 (31.75)	1.25 (31.75)	1.25 (31.75)	1.25 (31.75)
H- THREAD (N.P.T.)	1/2	1/2	5/8	5/8	3/4	3/4	3/4	3/4

• TO ORDER YOUR SPECIALS USE CODING CHART - SEE PG. 4-14

STANDARD ADAPTERS

Cap and Electrode Hex Adapters Pipe Thread

EXAMPLE EXPLANATION CODING

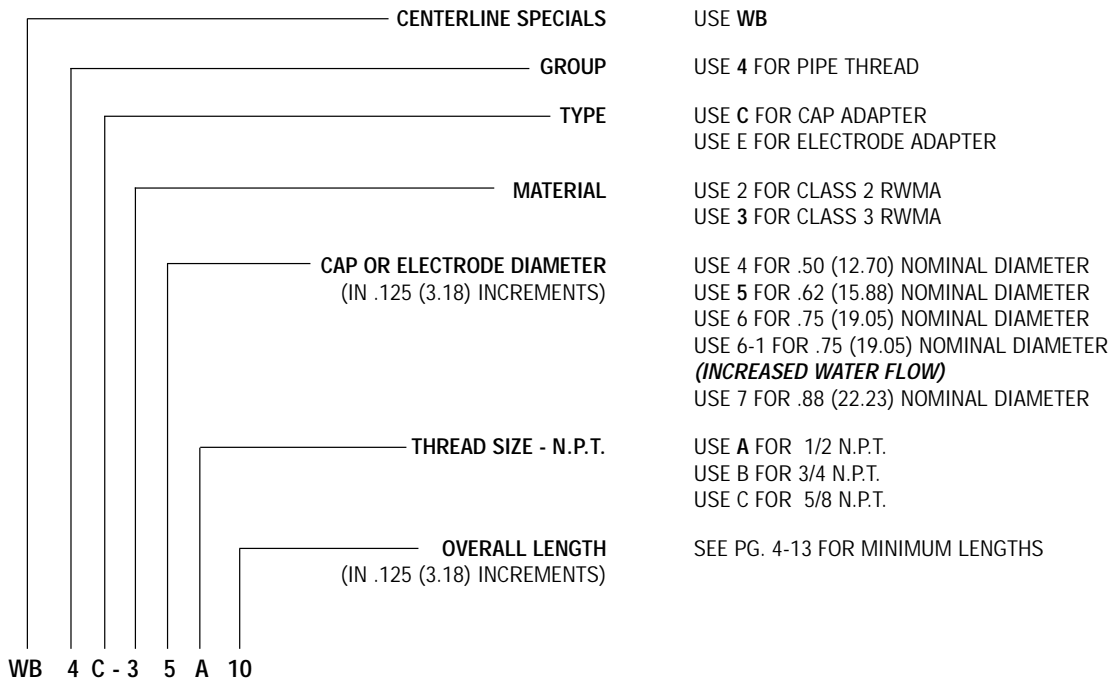

SAMPLE TYPICAL THREADED ADAPTER CODING

- _____ ADAPTER WILL BE 1.25 (31.75) LONG
- _____ ADAPTER WILL HAVE 1/2 N.P.T. (THREAD SIZE)
- _____ ADAPTER WILL BE USED WITH .62 (15.88) DIAMETER CAP
- _____ ADAPTER WILL BE MADE OF CLASS 3 RWMA
- _____ ADAPTER WILL BE MADE FOR CAP TYPE ELECTRODE
- _____ ADAPTER WILL HAVE PIPE THREAD

EXAMPLE:

- **WB4C-35A10**

• Dimensions Shown Are: inches (mm)