

FIXED UNIT HYDRAULIC EQUALIZING ASSEMBLIES

CMW Hydraulic Equalizing adapter units are used to equalize the weld force when two or more welds are required simultaneously. The equalizing action is developed in a closed hydraulic system - and is accomplished by hydraulically interconnecting two or more units. We recommend using fire resistant hydraulic fluid compatible with BUNA "N" such as HOUGHTO-SAFE #620, 1120 or equivalent. Consult your local industrial lubricant distributor.

TWO #1 OR #2 SIZE HYDRAULIC UNITS MOUNTED TO CUSTOMER'S DESIRED ELECTRODE SPACING.*

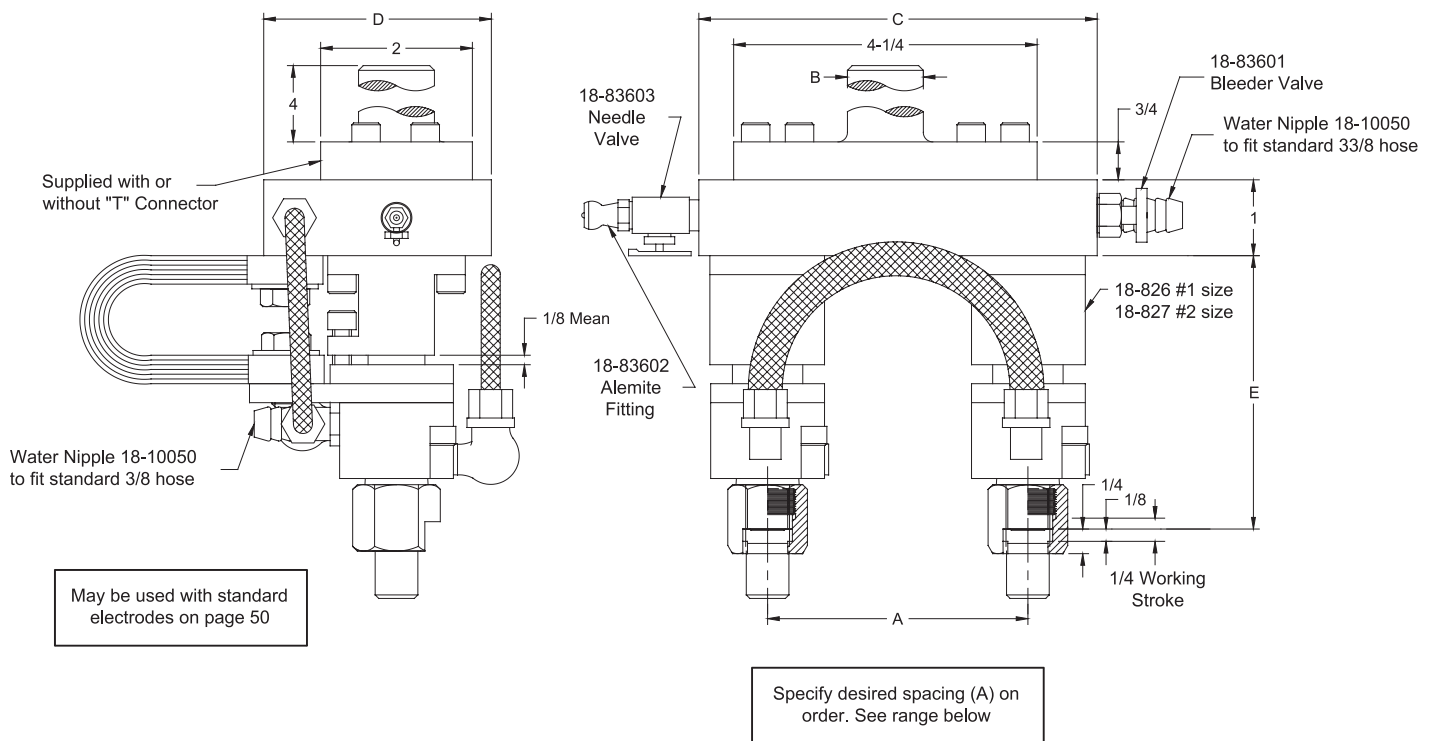

Assembly Unit Part No.	Unit Size	"T" Connector Shank Dia. B	Base Plate Length C	Base Plate Width D	Spacing* (Specify on Order) A	Max. Recommended Weld force Per Electrode LBS	Mean Height to Electrode Base E
18-846 18-84601-01	#1	None 1"	6	3	1-1/32" to 5"	1000 (12,000 Amps @ 10% duty cycle)	3-13/64
18-84601-02 18-84601-03		1-1/4" 1-1/2"					
18-847 18-84701-01		#2					
18-84701-02 18-84701-03	1-1/4" 1-1/2"						

Note:

- Multiple units of 2-8 can also be supplied on custom designed base plates with or without "T" Connectors.
- Units may be modified with adapters for RW tapered caps and electrodes

Phone: 800-933-6779

Fax: 205-663-3221

Email: sales@nsrw.com

ADJUSTABLE HYDRAULIC EQUALIZING ASSEMBLY 18-836

Part No. 18-836 (shown below) is a typical assembly using two 18-826 assemblies set up as a complete self-contained unit for making two spot welds at one time. **This unit is so arranged as to allow the center distances to be readily adjusted from 1-3/32" centers to 2-1/4" centers or by rearrangement of the same parts centers may be adjusted from 2-1/4" to 3-1/2".** This setup also include facilities for filling and bleeding the hydraulic units. "T" Mounting 18-83614 is available to order for assembly 18-836. We recommend using fire resistant hydraulic fluid compatible with Buna "N" such as HOUGHTO-SAFE #620, 1120 or equivalent. Consult your local industrial lubricant distributor.

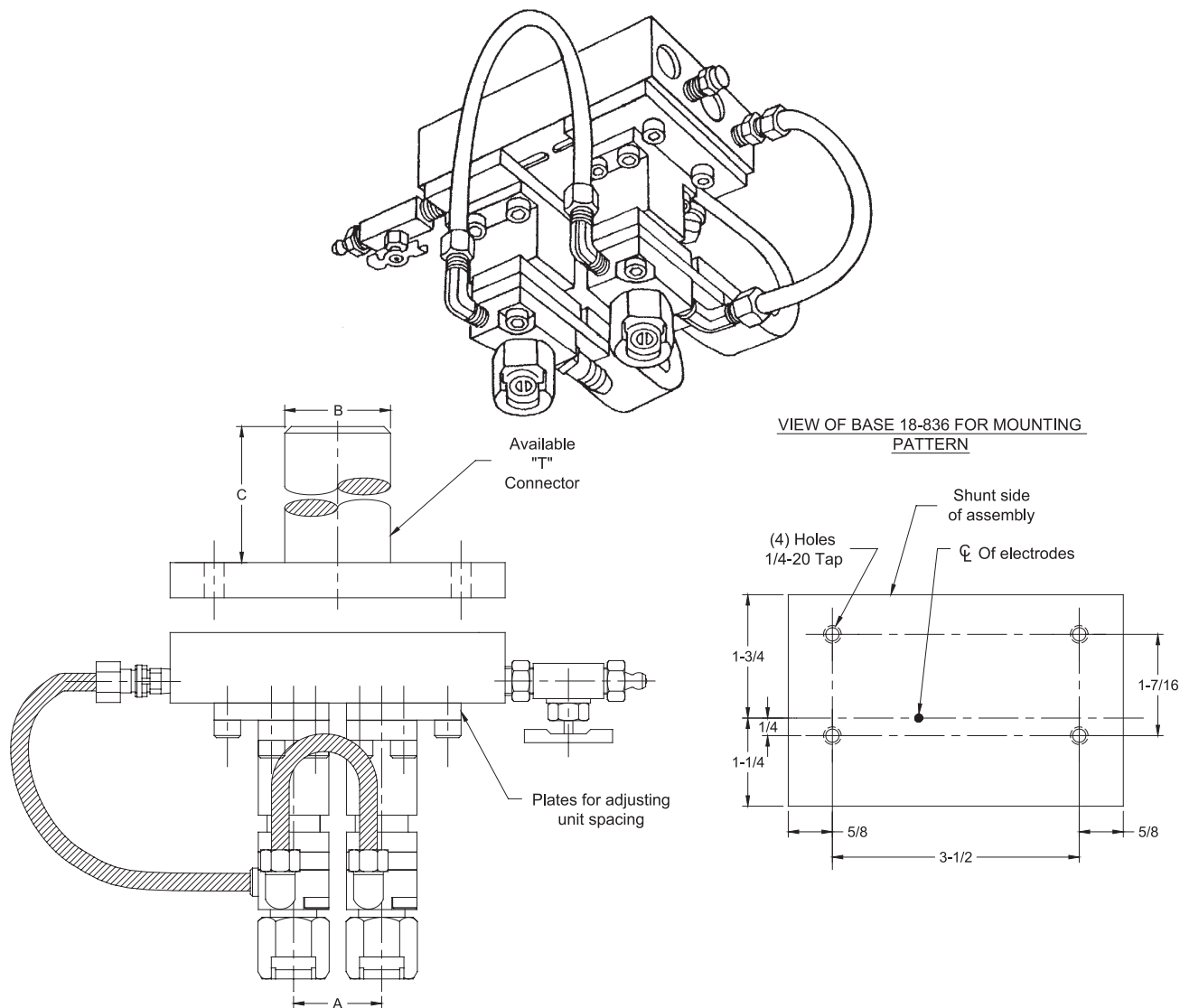

Assembly Part No.	Hydraulic Unit Size	Electrode Attachment ***	Adjustable Spacing Range A	"T" Connector	Max. Recommended Weld force Per Electrode LBS	
18-836	#1	#1 NU-TWIST®	1-1/32 - 2-1/4 2-1/4 - 3-1/2*	NONE	1000 (12000 AMPS @ 10% Duty Cycle)	
				Available	Dia. B	Length C
				18-83614-01	**	4
				18-83614-03	**	**

* Partial disassembly, rearrangement of plates, and bleeding of unit will be necessary to switch centerline ranges.

** Customer must specify dimensions desired.

*** Other attachments available on request