

1100 SERIES ADJUST-A-PRESSURE WATER COOLED LOW INERTIA ELECTRODE HOLDERS

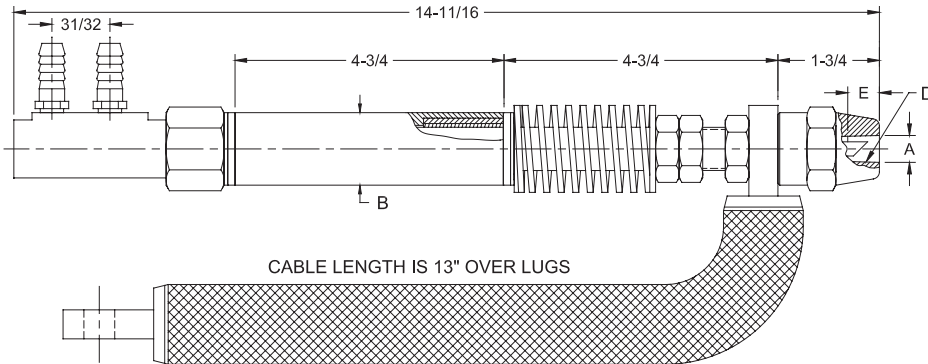
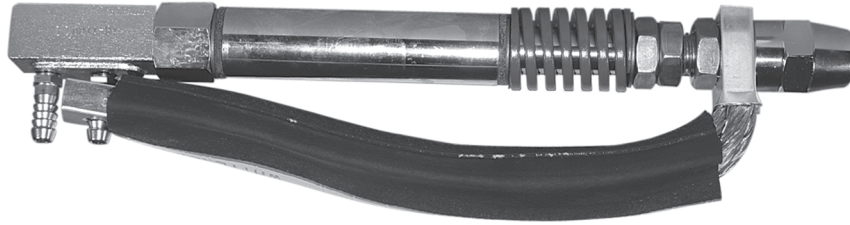

Like other low-inertia holders the heavy duty Adjust-A-Pressure Holders are used for multiple spot and projection welding, and are excellent for indirect welding when mounted in the Adjust-A-Angle Adapter.

Electrical current is conducted through heavy flexible cables and holder is installed to prevent any damaging effects to the spring mechanism. Light duty springs supplied to order.

Part No. Holder Assy.*	Major Taper Dia. A	Barrel Dia. B	Taper D	Standard Electrode Taper Engagement E	Pressure Range (Pounds)
18-1101	.463	1-1/4	4 RW	1/2	to 500
18-1102	.625		5 RW	3/4	
18-1103	.463	1-1/2	4 RW	1/2	
18-1104	.625		5 RW	3/4	

* Standard holder uses 18-110006-1 spring. A heavy duty holder is available with spring 18-110006-2 for pressure to 1000 lbs.

For additional holder information and replacement parts see page 59.

1150 SERIES ADJUST-A-ANGLE ADAPTERS

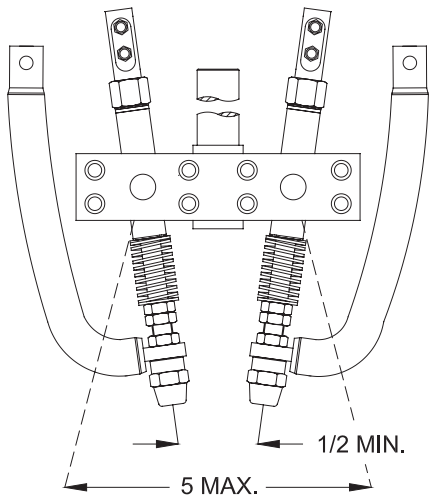

1100 SERIES HOLDERS ASSEMBLED IN 1150 SERIES ADAPTER

1150 SERIES ADJUST-A-ANGLE ADAPTERS ARE ADAPTABLE FOR USE WITH SPRING TYPE LOW INERTIA HOLDERS 1100 SERIES AS WELL AS STRAIGHT HOLDERS 100, 200, AND 300 SERIES.

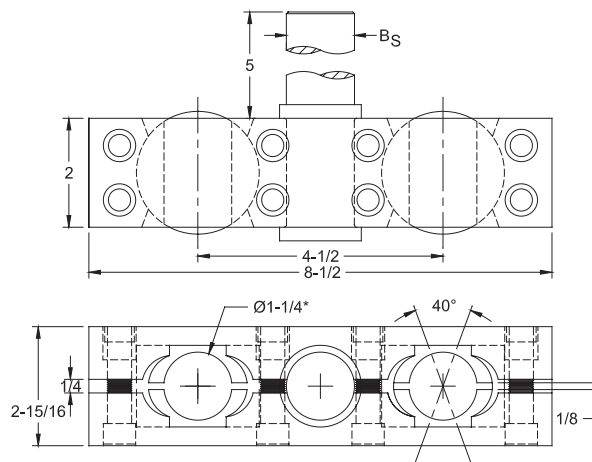

Adapter Assembly Part No.	Shank Dia. B _S
18-1154	1
18-1155	1-1/4
18-1156	1-1/2

* Adapters for barrel sizes other than 1-1/4 dia. available as special order